

POE splitter

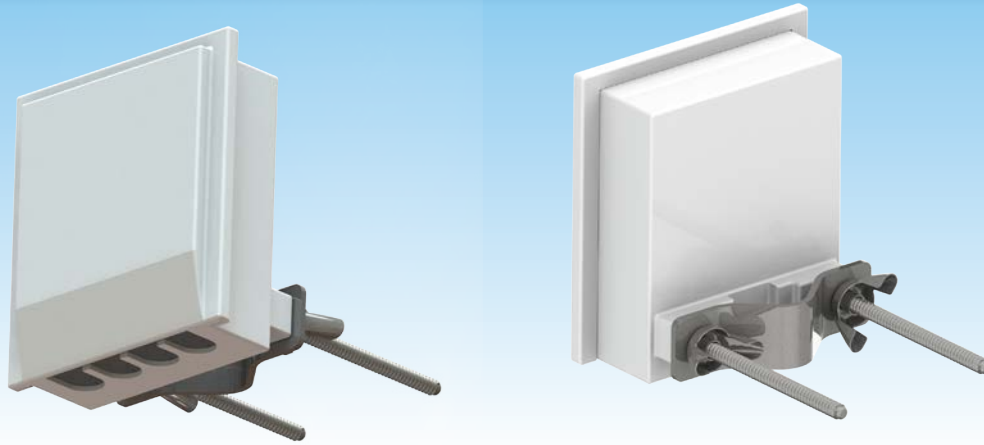

ESD and surge protection	15 kV ESD protection, 4 kV line to ground protection, 2 kV line to line protection
Interfaces	3 x 100 Base-T
Mounting	Wall and pole mounting (max pole width 50 mm or 2 inch)
Size (W x H x L)	85.7 x 91.5 x 43.9 mm (111.5 with mounting) (3.37 x 3.6 x 1.73 inch (4.39 with mounting).
Weight	140 g (0.31 lb)

Video surveillance scenario

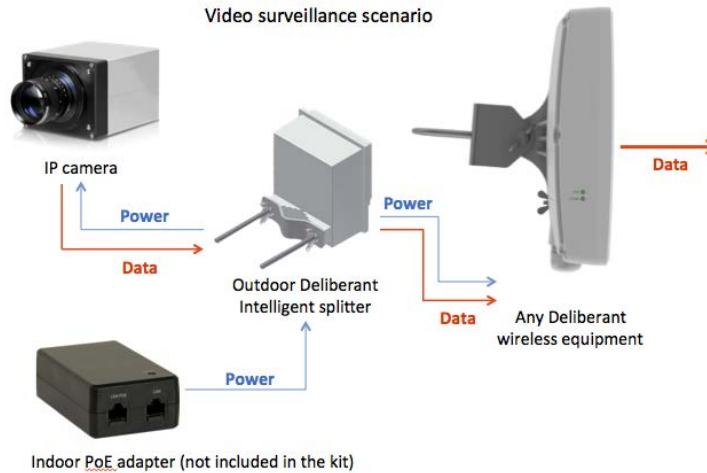

Repeater scenario

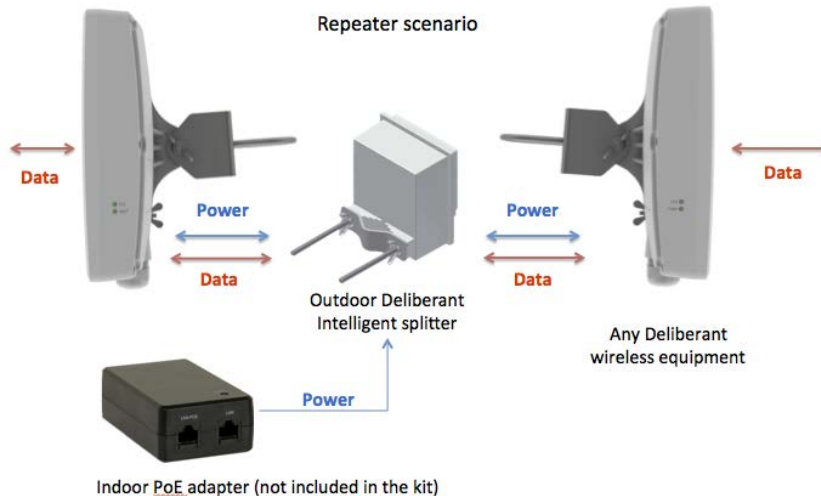

Copyright © 2012 Deliberant LLC. All rights reserved. Deliberant, the Deliberant logo, are trademarks of Deliberant LLC. All other company and product names may be trademarks of their respective companies. While every effort is made to ensure the information given is accurate, Deliberant does not accept liability for any errors or mistakes which may arise. Specifications and other information in this document may be subject to change without notice.

To learn more about Deliberant products, visit www.deliberant.com.





www.deliberant.com

Copyright © 2012 Deliberant LLC. All rights reserved. Deliberant, the Deliberant logo, are trademarks of Deliberant LLC. All other company and product names may be trademarks of their respective companies. While every effort is made to ensure the information given is accurate, Deliberant does not accept liability for any errors or mistakes which may arise. Specifications and other information in this document may be subject to change without notice.



To learn more about Deliberant products, visit www.deliberant.com.